

WALWORTH COUNTY METROPOLITAN SEWERAGE DISTRICT

SANITARY SEWER CONSTRUCTION STANDARDS (Gravity Sewer, Manholes, and Laterals) Effective September 9, 2008.

1. GENERAL

- A. The purpose of the WalCoMet Sewer Construction Standard is to require construction methods that will reduce Clearwater infiltration and inflow into the collection system. Entities may have additional standards to address items not included in the WalCoMet Standards, or may elect to have Standards that are more stringent than the WalCoMet Standards.
- B. The WalCoMet Sewer Construction Standard includes provisions for sanitary sewers and the associated laterals and manholes. Provisions for items not included in the WalCoMet Construction Standard shall be as specified in the “Standard Specifications”.
- C. “Standard Specifications” in the WalCoMet Sewer Construction Standard refers to the latest edition of the Standard Specifications for Sewer and Water Construction in Wisconsin.

2. SANITARY SEWERS

A. Pipe Materials

- i. Polyvinyl Chloride Sewer Pipe (PVC): All PVC pipe shall be as specified in Chapter 8.10.0 of the Standard Specifications and as modified herein. Pipe shall be of appropriate strength for conditions and loading. Minimum class for PVC pipe 15-inches in diameter or less shall be SDR-35 conforming to ASTM D-3034 or DR18 conforming to AWWA C-900. PVC pipe 18-inches in diameter and greater shall conform to ASTM F-679 with a minimum pipe stiffness of 46 psi. Rubber Gaskets, conforming to Chapter 8.10.6(a) of the Standard Specifications shall be used. PVC pipe shall be marked in accordance with Chapter 8.10.4 of the Standard Specifications.
- ii. Reinforced Concrete Pipe (RCP): All RCP pipe shall be as specified in Chapter 8.6.0 of the Standard Specifications, and as modified herein. RCP pipe shall meet the requirements of ASTM C76. Minimum class shall be Class III. Wall thickness shall be in accordance with Chapter 8.6.3 conforming to column Wall C (C-Wall). RCP joints shall be Type R-4 with rubber gaskets conforming to Chapter 8.41.2 of the Standard Specifications. RCP pipe shall be marked in accordance with Chapter 8.3.1 of the Standard Specifications.
- iii. Lateral Connections for new construction shall use fabricated wye connections (not break-in). Prefabricated Fittings shall conform to Chapter 8.10.5 of the Standard Specifications. Specialized fittings such as Kor N Tee, or equal, shall be used for connections to existing sewers.

- iv. Riser connections shall use fabricated tee or wye connections. Risers shall be enclosed in a fibrous or other approved form with a diameter two and one-half times the pipe diameter. The space between the form and the pipe shall be filled and the trench compacted as shown on File 10 of the Standard Specifications. Flowable fill may be used below the riser in lieu of compacted granular backfill.
- v. Joints for Lateral Connections shall conform to Chapter 8.10.6 of the Standard Specifications.
- vi. When it is impossible to obtain the proper horizontal and vertical separation from potable water systems, such as wells or water mains, sanitary sewers shall be constructed of materials and with joints that are equivalent to water main standards of construction and pressure tested to assure water tightness.
- vii. Installation of sewers using trenchless construction methods shall conform to Chapter 6 of the Standard Specifications.

B. Testing of Installed Pipe

- i. The entire length of PVC Sewers shall have Deflection Test completed in accordance with Chapter 3.2.6(i)(4) and File No. 30, Part IX, of the Standard Specifications. A Deflection limit of 5% shall be used.
- ii. All Sewers with diameters of 36 inches and smaller shall have a Low Pressure Air Test completed in accordance with Chapter 3.7.0 and File 31, Part IX, of the Standard Specifications.
- iii. All sewers with diameters greater than 36 inches shall have infiltration tests completed in accordance with Chapter 3.7.0 and File 31, Part IX, of the Standard Specifications.

3. SANITARY SEWER LATERALS

- A. Pipe Materials shall be SDR-35 conforming to ASTM D-3034 and Chapter 8.10.0 of the Standard Specification, and with rubber gaskets conforming to ASTM F-477.
- B. When it is impossible to obtain the proper horizontal and vertical separation from potable water systems, such as wells or water mains, laterals shall be constructed of materials and with joints that are equivalent to water main standards of construction and pressure tested to assure water tightness.

4. SANITARY MANHOLES

A. Materials

- i. All Sanitary manholes shall be Precast Reinforced Concrete Manholes with integral bases in accordance with Chapter 3.5.0, 8.39.0, and File No. 12, Part IX, of the Standard Specifications,
 - a. Refer to File No. 12, Part IX, of the Standard Specification, for manhole diameters, except that the manhole diameter for pipes diameters of 8" thru 30" shall be 4'-0"
 - b. Outside drop manholes shall be constructed in accordance with File #19, Part IX, of the Standard Specifications. Pipe Drop shall be same diameter as incoming sewer.
 - c. Joints shall be in accordance with Chapter 8.39.5. Acceptable manufactures shall be Ramnek, Kent Seal or approved equal.
- ii. Manhole Castings shall conform to ASTM A-48, Class No. 35-B and shall be free from cracks, holes, swells and cold shuts. Covers shall be "self-sealing" with concealed pick holes, as shown on File 14B, Part IX, of the Standard Specifications.
- iii. Adjust castings to grade with reinforced concrete adjusting rings with a minimum thickness of 2 inches. Do not use more than 10 inches of adjusting rings.

B. Sealing Manholes

- i. All manholes shall have Internal Manhole Chimney Seals consisting of a flexible rubber sleeve, interlocking extensions, and stainless steel bands conforming to Chapters 8.42.3, 8.42.4 and 8.42.5 of the Standard Specifications and the applicable requirements of ASTM C-923. The seal and extension shall extend from the frame casting down to the top of the manhole cone. Cretex Specialty Products, Adaptor, Inc. or approved equal shall be used. Chimney seals shall be reset anytime the manhole frame is adjusted and reset.
- ii. An external sealing band meeting the requirements of ASTM C877, Type II, shall be placed on the outside of the manhole from the frame casting to below the top of the manhole cone. Acceptable manufacturers shall be Mac Wrap External Collar by Mac Wrap Construction Products Co., Cretex Wrap by Cretex Specialty Products, or approved equal.
- iii. All sanitary manholes shall have an exterior joint sealer applied to each joint, meeting the requirements of ASTM C-877, Type II. Acceptable manufacturers shall be MacWrap External Collar by Mac Wrap Construction Products Co. Inc., Cretex Wrap by Cretex Specialty Products or EZ-wrap by Press Seal Gasket Corporation. The sealer installation shall be approved by the Inspecting Engineer after application and prior to backfilling.

C. Pipe to Manhole Connections

- i. All sewer pipe/lateral to manhole connections for PVC Pipe shall be with an approved flexible, watertight pipe to manhole seal as specified in Chapter 3.5.7(c) of the Standard Specifications. "A-Lock", "Core Seal Boots" or approved equal.
- ii. All sewer pipe/lateral to manhole connections for RCP Pipe shall be with an approved flexible, watertight pipe to manhole seal as specified in Chapter 3.5.7(a) of the Standard Specifications.

- iii. Annular space between non-rigid pipe and manhole wall shall be plugged with flexible butyl rubber gasket material prior to pouring the manhole invert and bench. Gasket material shall be E-Z Stick or Kent Seal
- iv. Bulkheads for future pipe connections into the manhole shall be in accordance with File 13A, Part IX of the Standard Specifications.

D. Testing

- i. Vacuum testing of all sanitary manholes is required. Test shall be performed before installation of internal chimney seal.
 - a. Isolate the manhole to be tested by plugging the inlet and outlet pipes with an inflatable stopper or other suitable test plugs. The plugs shall be securely braced to avoid the plugs from being drawn into the manhole. Plug lift holes with non-shrink grout.
 - b. Inflate the seal to 40 psi to effect a seal between the base and the manhole. Run vacuum pump until a vacuum of 10 inches of mercury is obtained.
 - c. With vacuum pump shut off and the valve on the vacuum line of the test head closed, measure the time for the vacuum to drop to 9 inches of mercury. The manhole test is acceptable if the time exceeds the values listed in Table 1.

TABLE1: MINIMUM TEST TIMES IN SECONDS FOR VARIOUS MANHOLE DIAMETERS

Depth (ft)	Diameter (inches)			
	42	48	60	72
8	17	20	26	33
10	21	25	33	41
12	25	30	39	49
14	30	35	45	57
16	34	40	52	67
18	38	45	59	73
20	42	50	65	81
22	46	55	72	89
24	51	69	78	97
26	55	64	85	105
28	59	69	91	113
30	63	74	98	121

4. CONSTRUCTION INSPECTION

- A. Full time resident inspection of all sewer construction.
- B. Laterals to be inspected and approved by plumbing inspector prior to backfilling trenches.

WALCOMET SAMPLING MANHOLE DETAIL

REVISED

8-12-2008

PIPE CONNECTIONS SHALL BE MADE WITH RUBBER FLEXIBLE BOOTS WITH STAINLESS STEEL BANDS & LOCKED IN PLACE WITH LOC TITE RING KOR-N-SEAL OR EQUAL

PROVIDE EXTERNAL WATER TIGHT SEAL WITH USE OF TROWELABLE BUTYL RUBBER ON CHIMNEY SECTION OF MANHOLE

NOTE: 10 TIMES PIPE DIAMETER STRAIGHT UPSTREAM FROM MANHOLE REQUIRED

FLOW FROM STRUCTURE

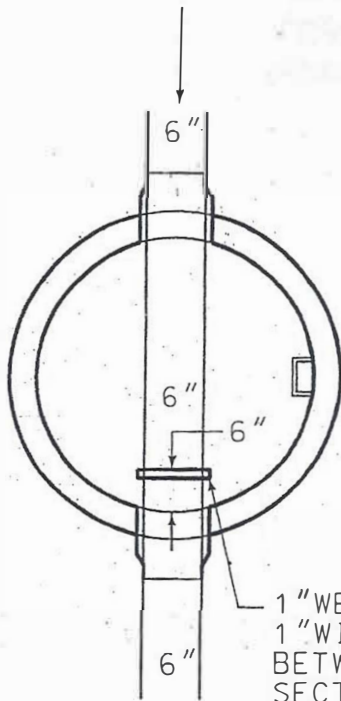

TO:
PUBLIC
SYSTEM

CONTACT WALWORTH COUNTY METROPOLITAN SEWERAGE DISTRICT FOR SLIP IN FLUME INFORMATION @ (262)728-4140

BEDDING MATERIAL

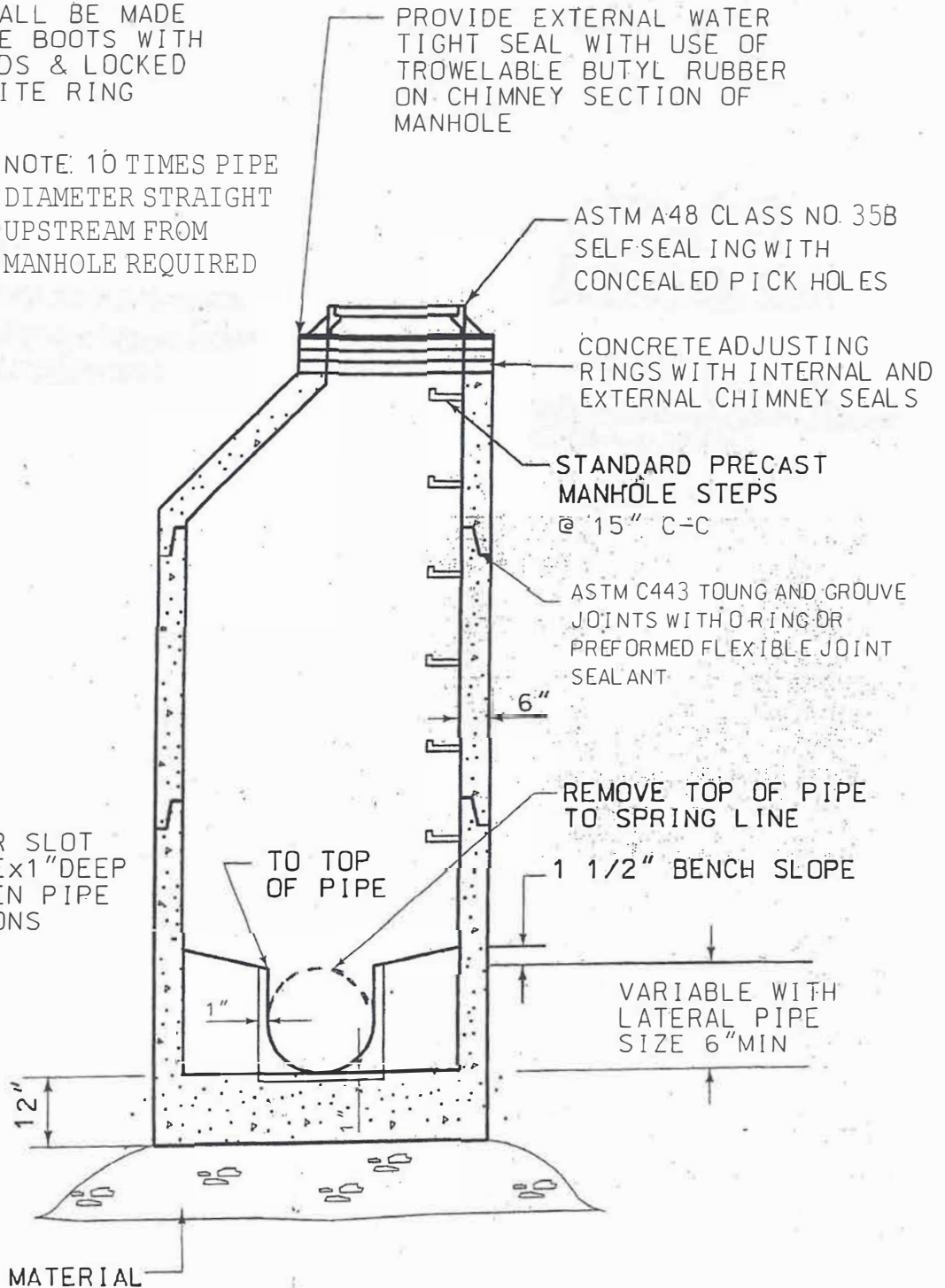

NOTE:

Refer to the Walworth County Metropolitan Sewerage District's Sanitary Sewer Construction Standards effective as of September 9, 2008.